

Tekform Slimline+ Drawer

Assembly instructions

Titus+

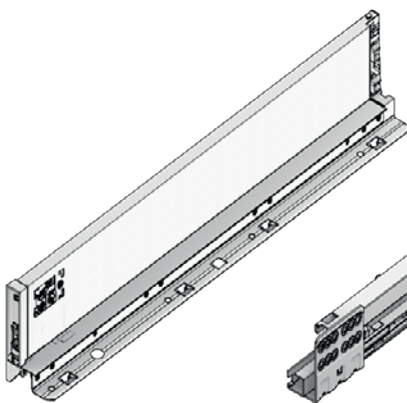
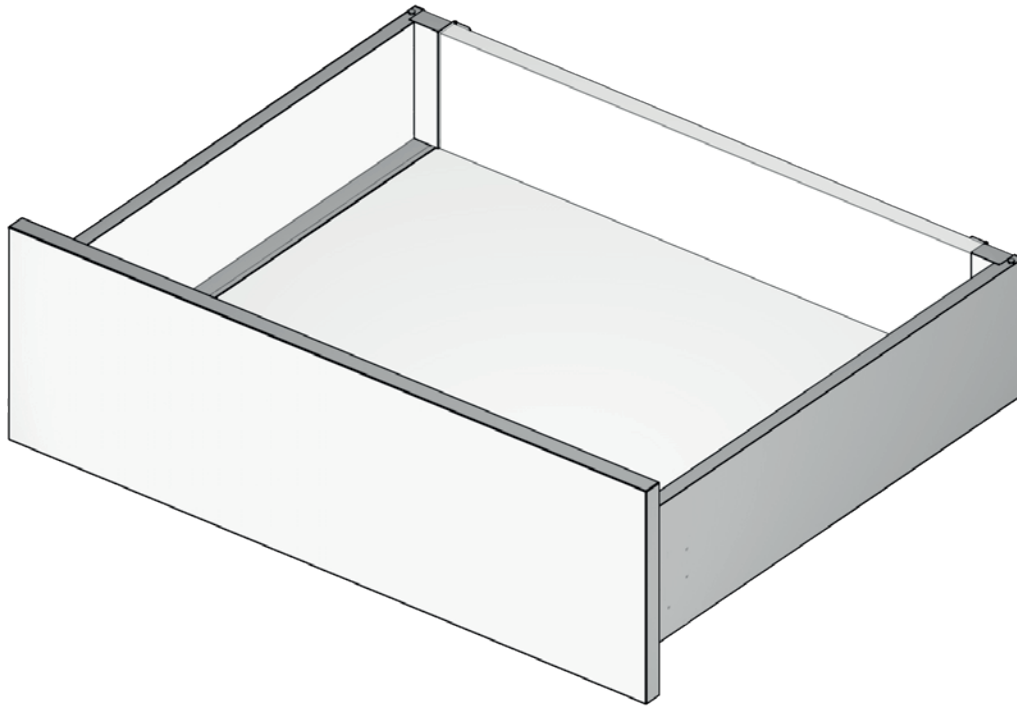

2x

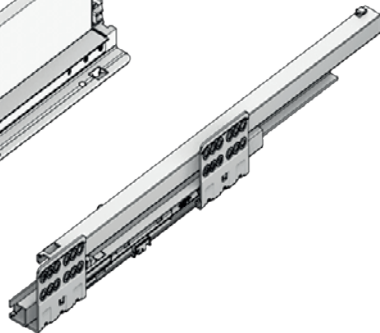

2x



2x

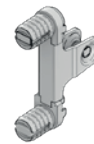

2x



2x

Tool needed for assembly

PZ2

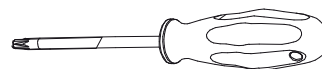

Recommended screws (not included)

Ø6.3 x 13mm



Ø3.5 x 15mm





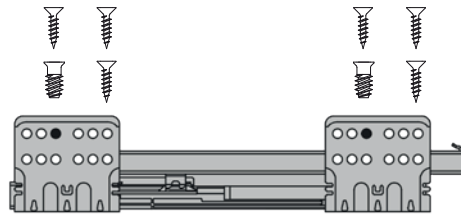

Tekform Titus+

Runner mounting

i



Ø6.3 x 13mm  
 Ø3.5 x 15mm  



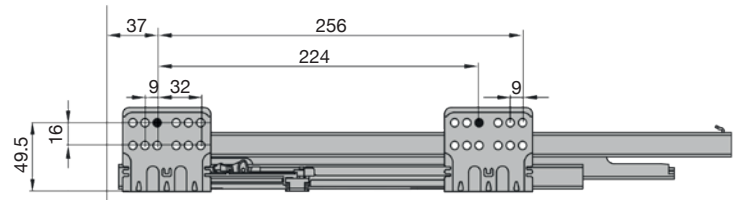
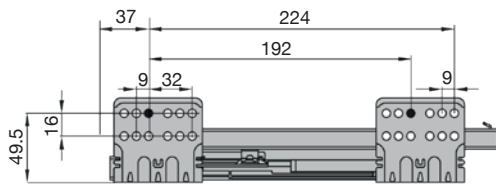

NL=270 mm
 NL=300 mm
 NL=350 mm
 NL=400 mm
 NL=450 mm

NL=500 mm
 NL=550 mm

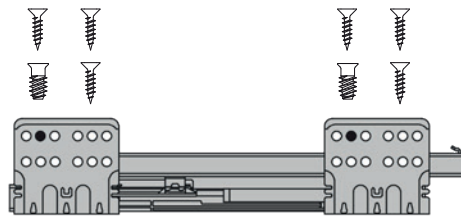

i



Ø6.3 x 13mm  
 Ø3.5 x 15mm  

NL=270 mm
 NL=300 mm
 NL=350 mm
 NL=400 mm
 NL=450 mm

NL=500 mm
 NL=550 mm

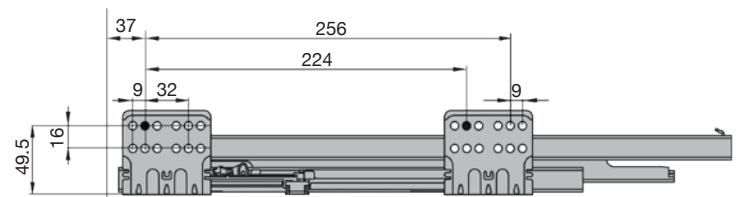
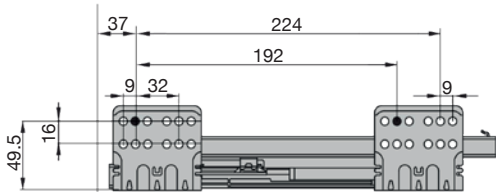

Planning

i

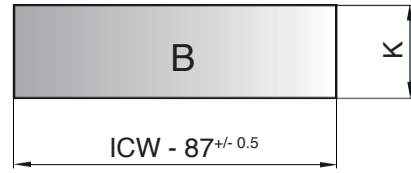
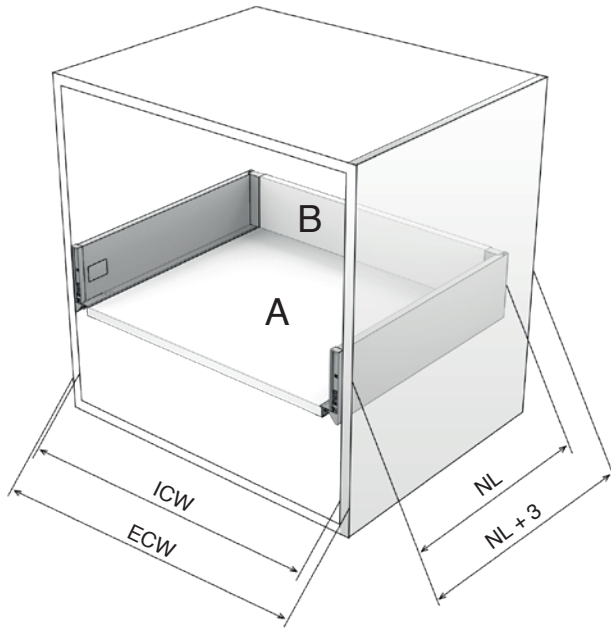

DW70	K=68
DW100	K=100
DW145	K=151
DW182	K=183

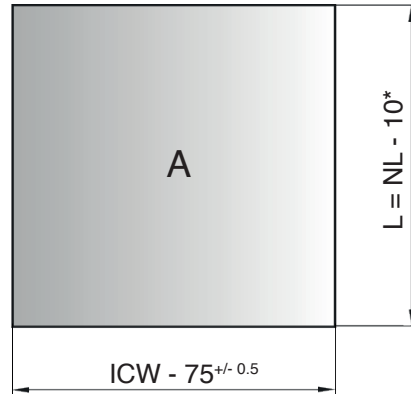

* For drawers with steel back panel
L = NL - 20

Front Panel Dimensions and Drilling

i DW70

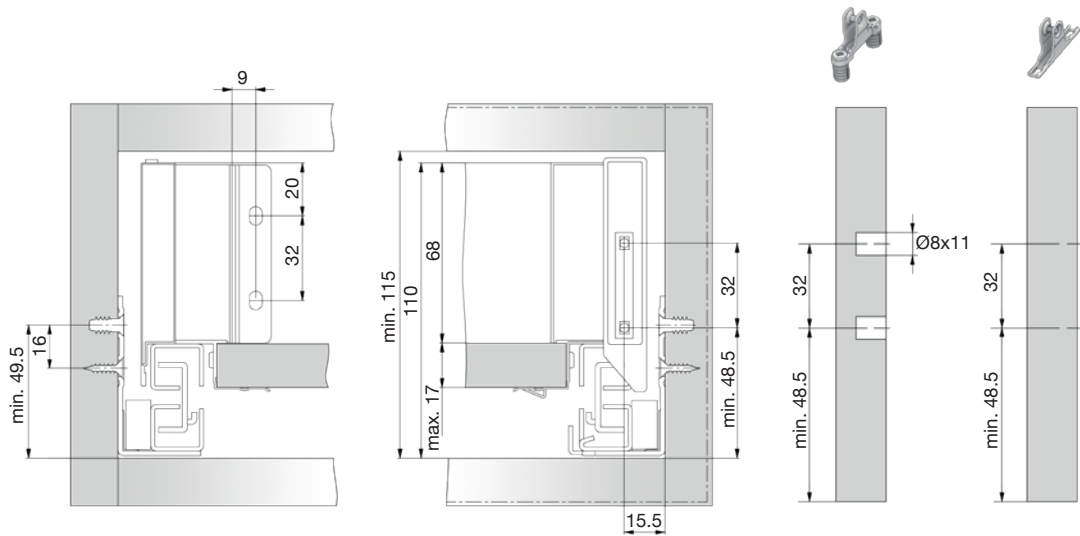

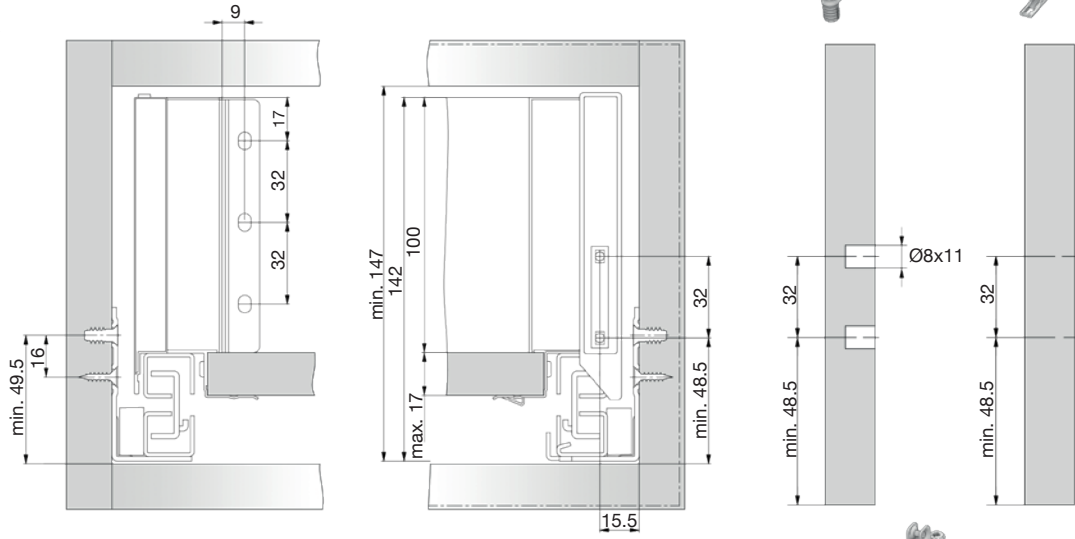
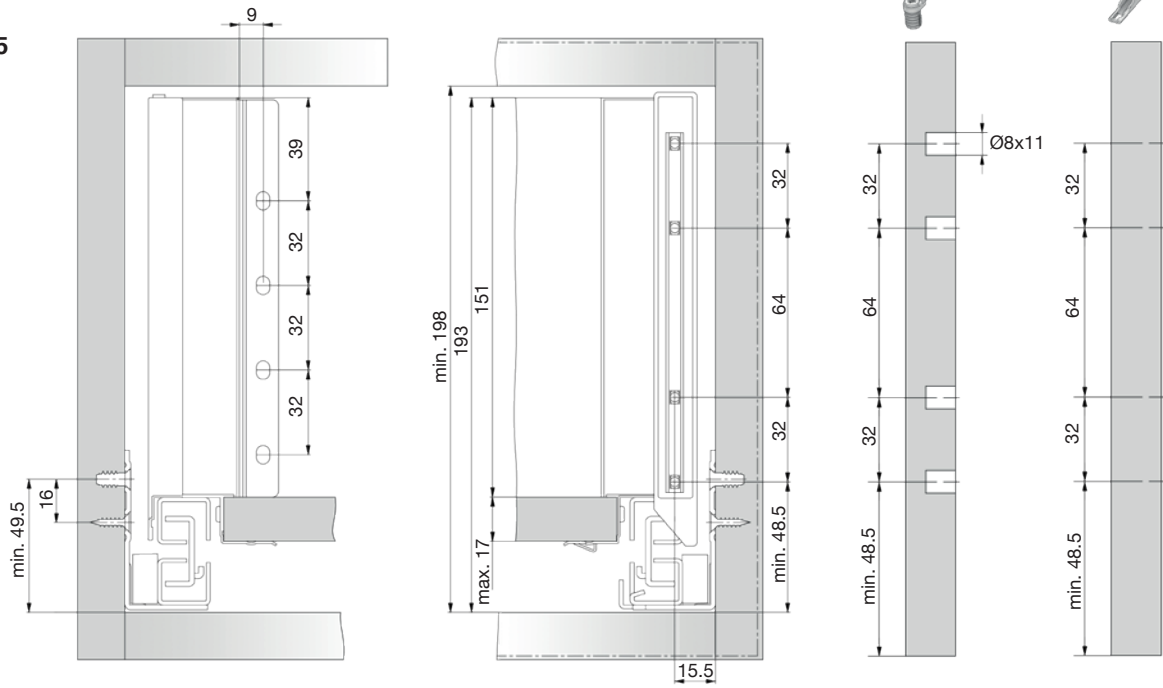
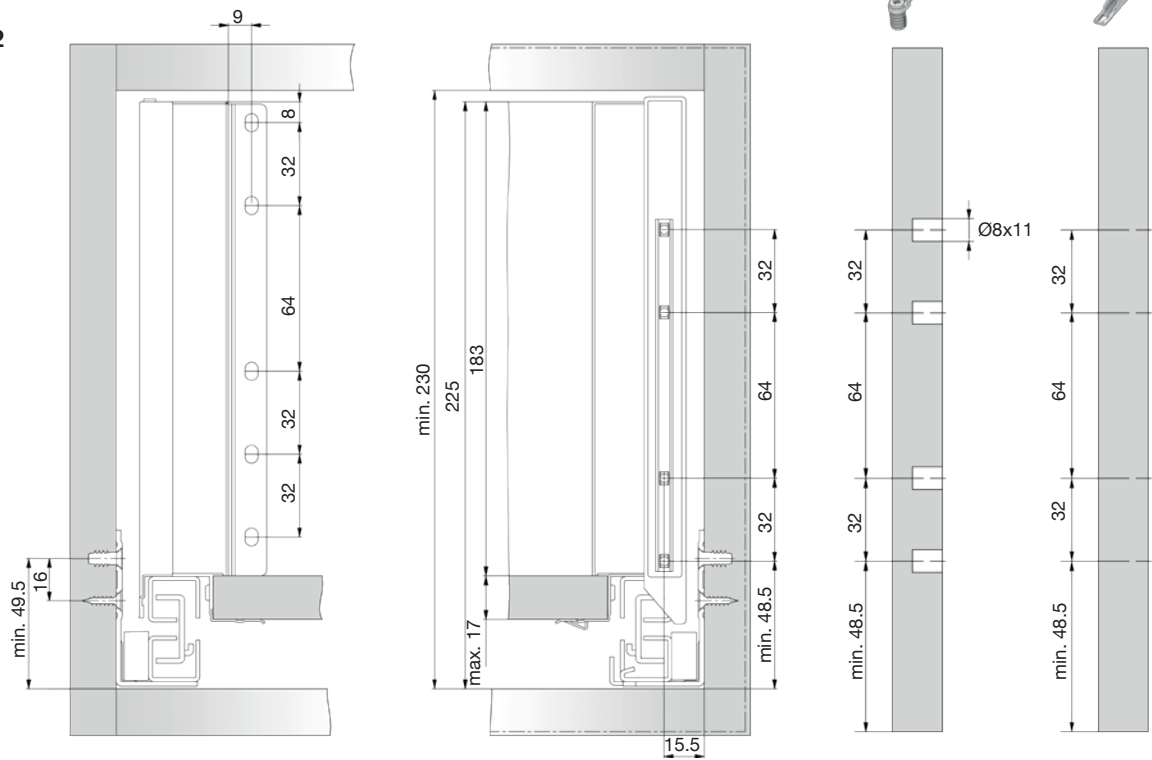
i**DW100****DW145****DW182**

Assembly wooden back panel

1

2x

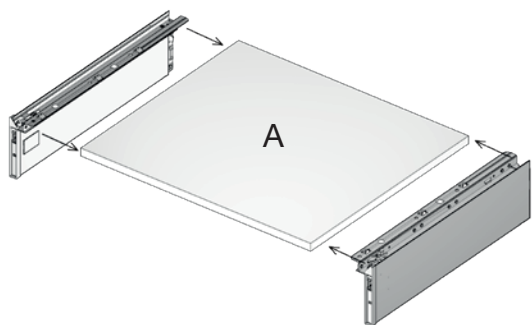

8x

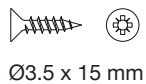

Ø3.5 x 15 mm

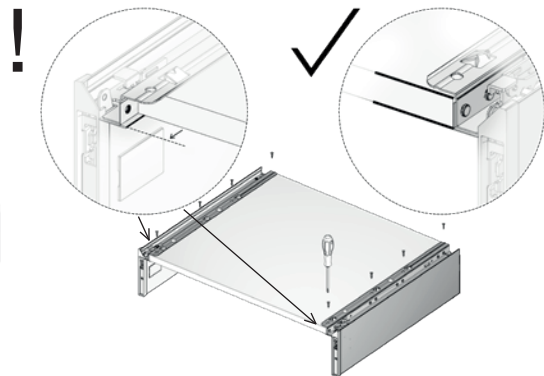

2

2x

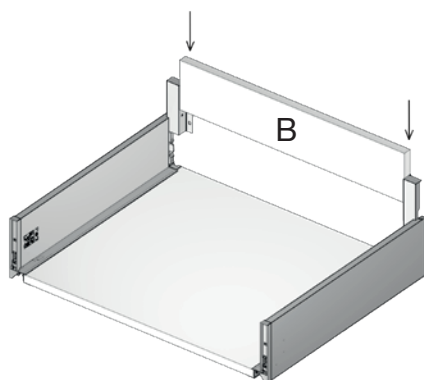

4x

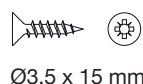

Ø3.5 x 15 mm

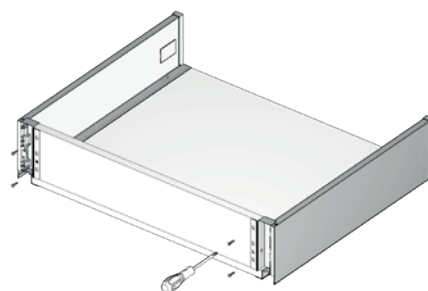

Assembly steel back panel

1

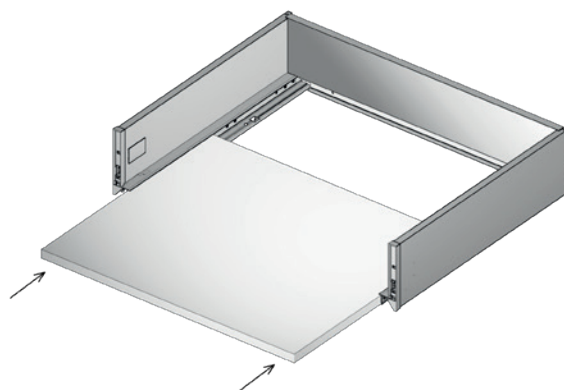
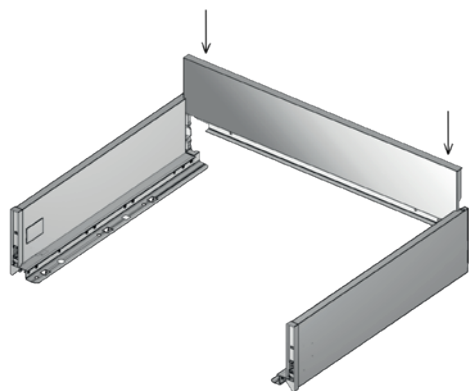

2

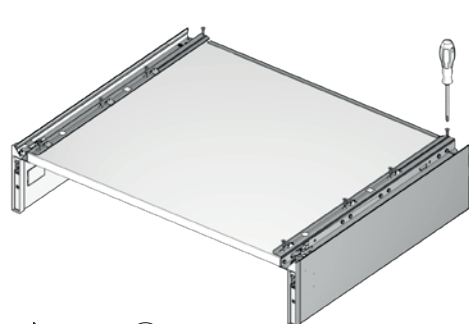

8x

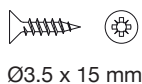

Ø3.5 x 15 mm

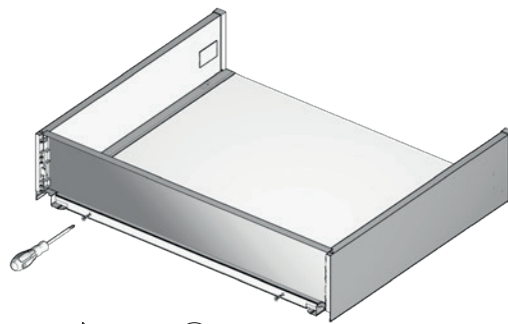

2x

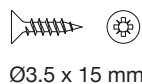

Ø3.5 x 15 mm

Insertion of Front Connectors

3

2x



4x



Ø3.5 x 15 mm

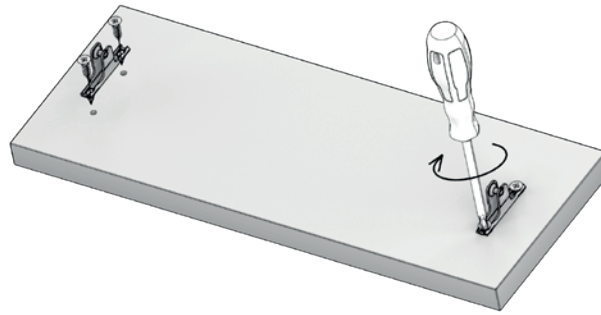

2x

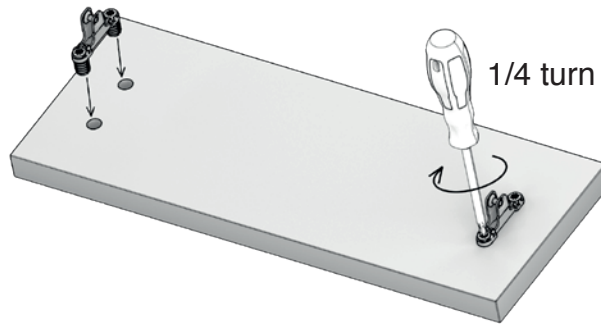
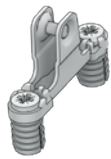

1/4 turn

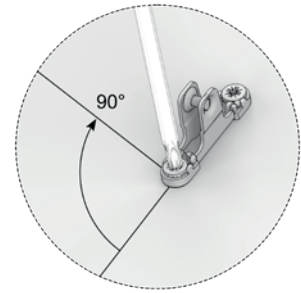

Front Panel Mounting

4

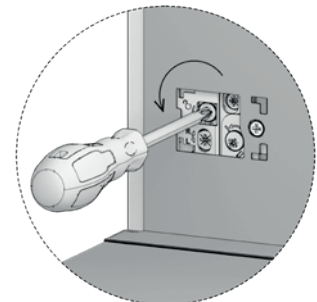
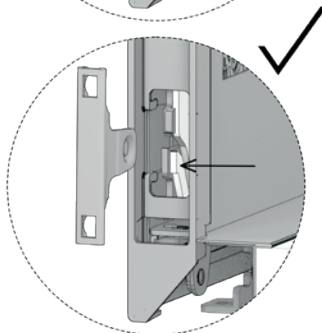
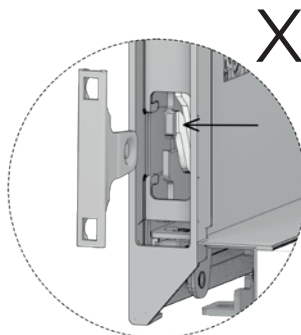

Drawer Insertion

5

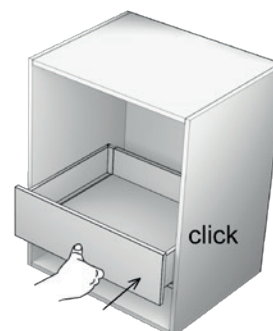
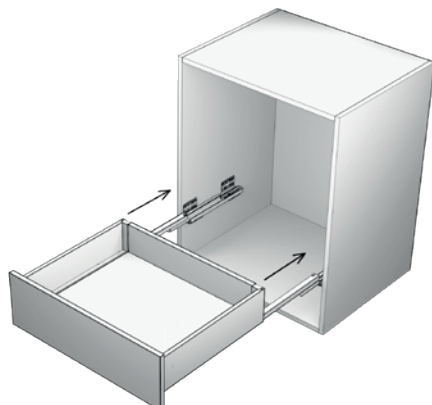

Adjustments

i

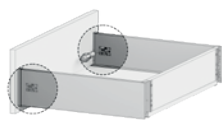

Side adjustment

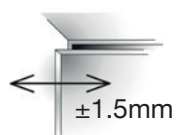

Height adjustment

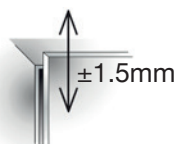

Tilt adjustment

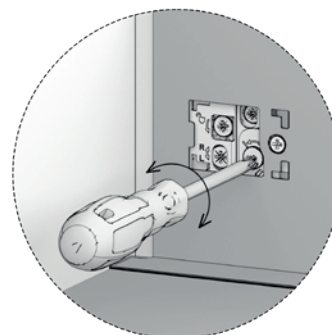
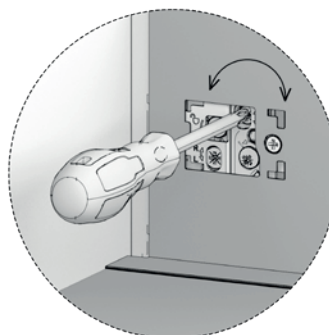
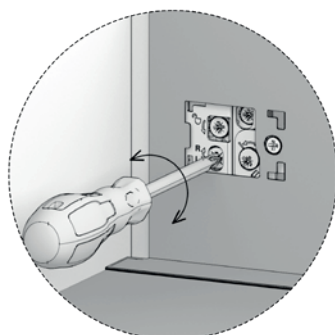

Drawer removal

i

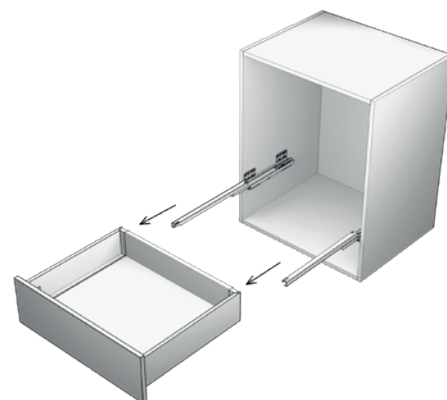
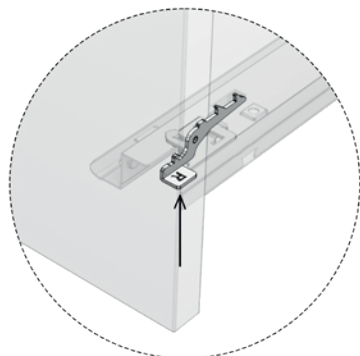
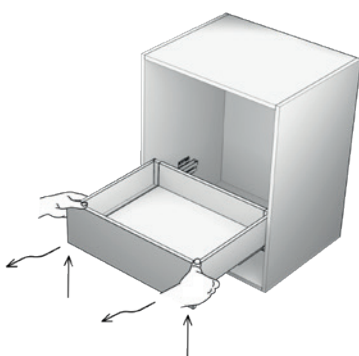

Front panel removal

i

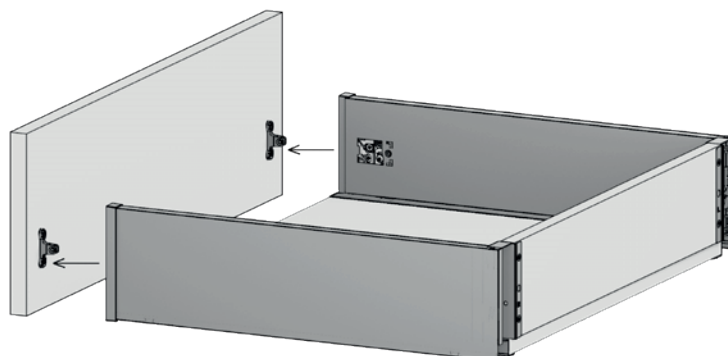
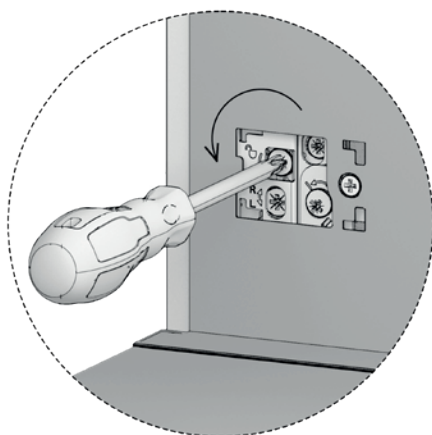

Assembly of Inner Drawer Front

1 Cutting dimensions

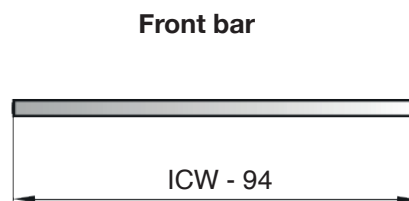
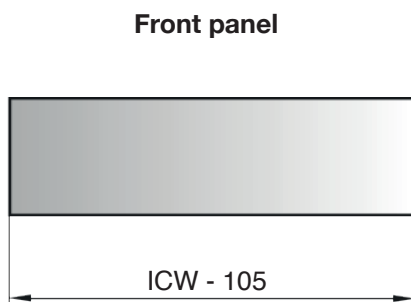

2 Slimline+ DW70

2x



1x

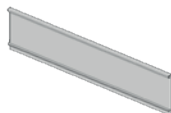

4x

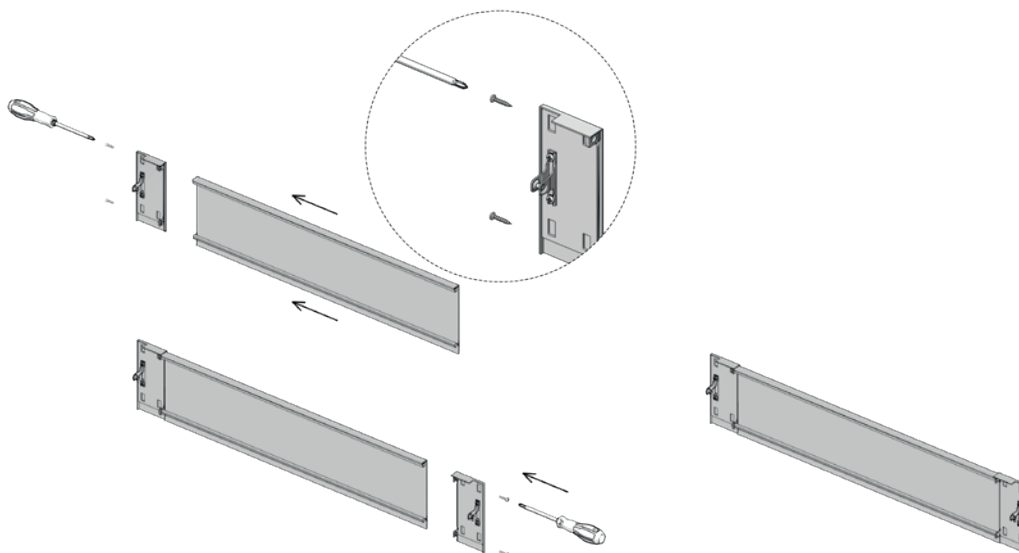

Slimline+ DW145 / DW182

2x



1x



1x



4x

