

Tekform Slimline+ Drawer

Assembly instructions

Titus+

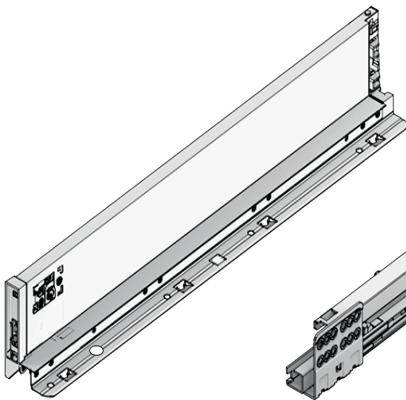
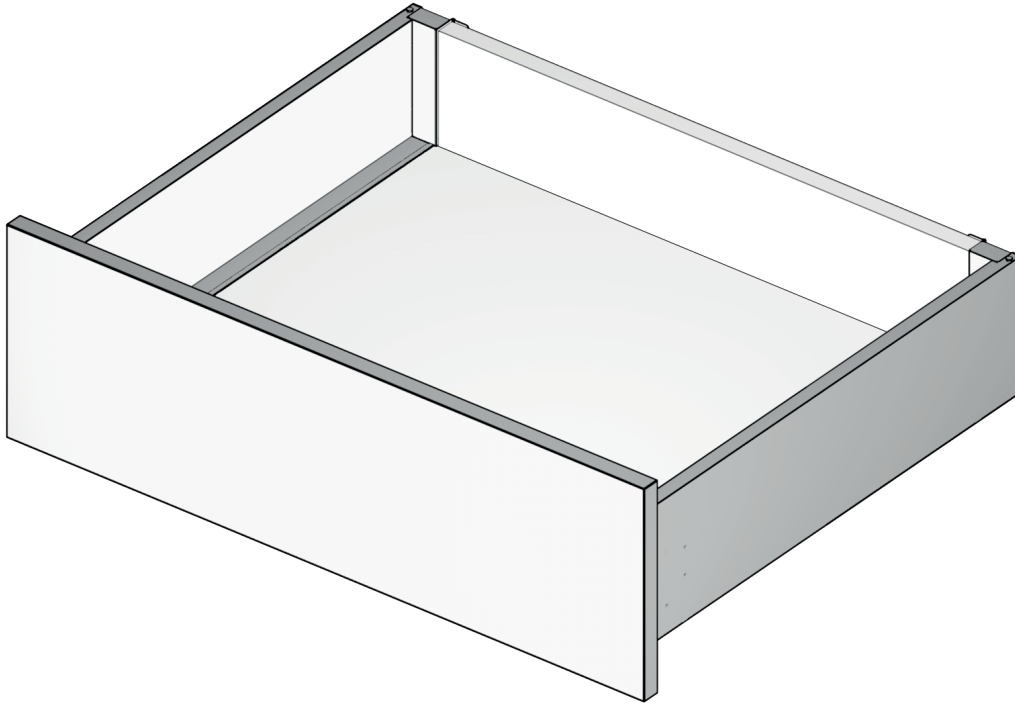

2x

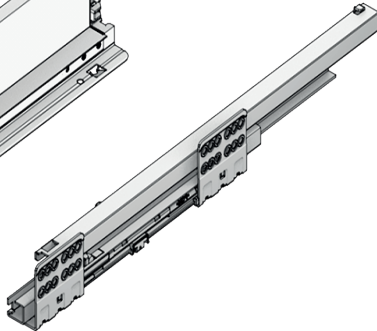

2x



2x

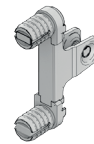

2x



2x

Tool needed for assembly

PZ2

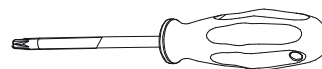

Recommended screws (not included)

Ø6.3 x 13mm



Ø3.5 x 15mm



Tekform
Titus+

Runner mounting

i

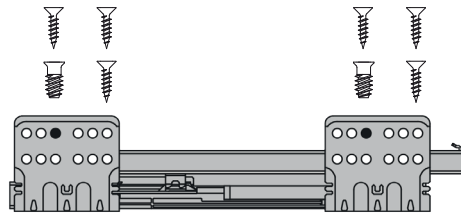
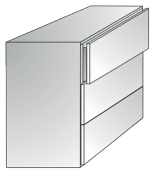

- Ø6.3 x 13mm
- Ø3.5 x 15mm

NL=270 mm
 NL=300 mm
 NL=350 mm
 NL=400 mm
 NL=450 mm

NL=500 mm
 NL=550 mm

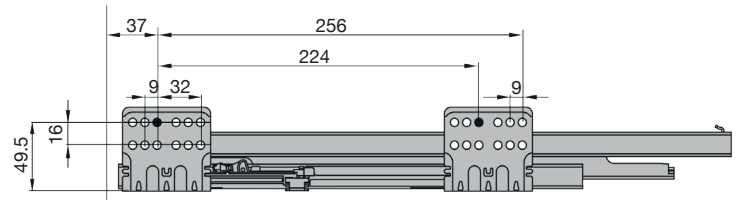
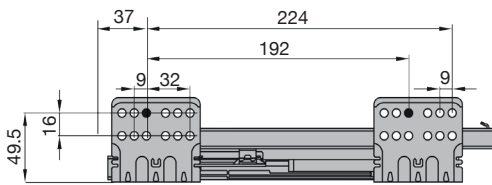

i

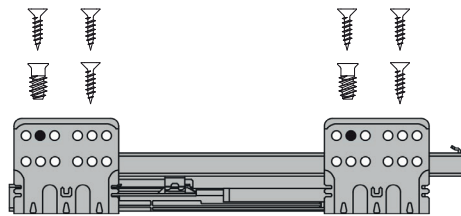

- Ø6.3 x 13mm
- Ø3.5 x 15mm

NL=270 mm
 NL=300 mm
 NL=350 mm
 NL=400 mm
 NL=450 mm

NL=500 mm
 NL=550 mm

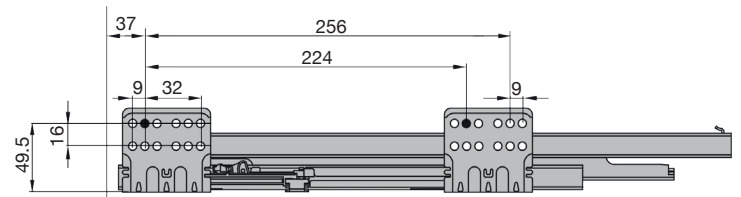
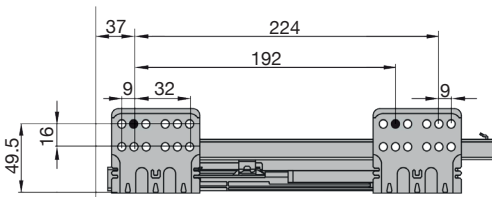

Planning

i

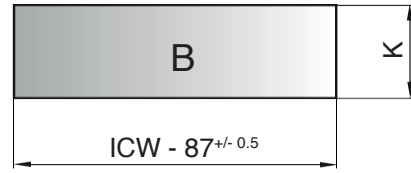
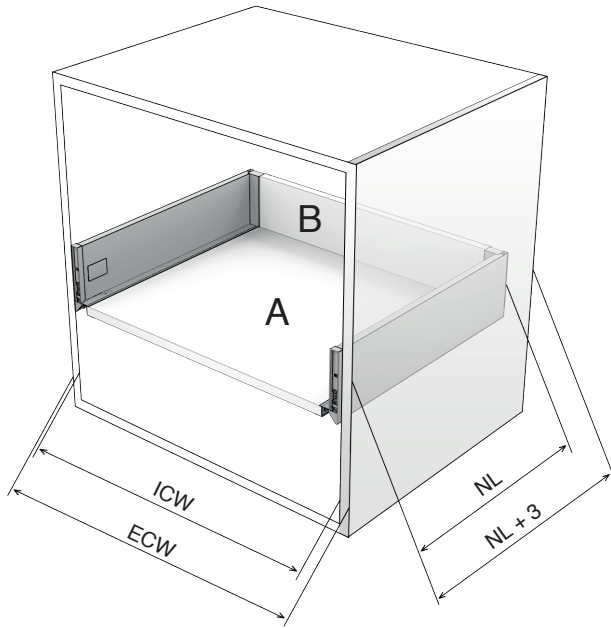

DW70	K=68
DW100	K=100
DW145	K=151
DW182	K=183

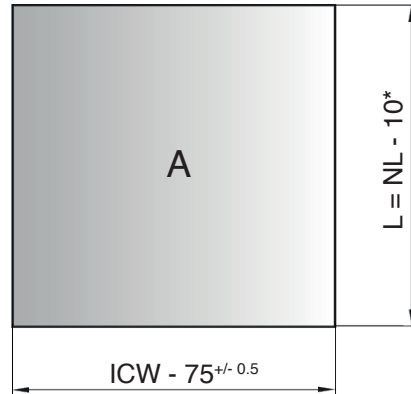

* For drawers with steel back panel
L = NL - 20

Front Panel Dimensions and Drilling

i

DW70

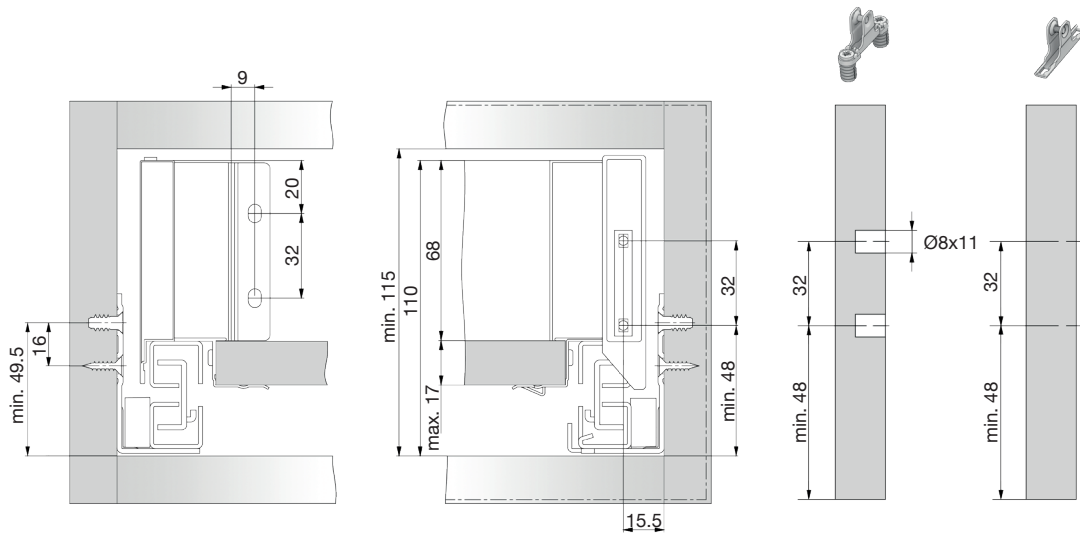

i

DW100

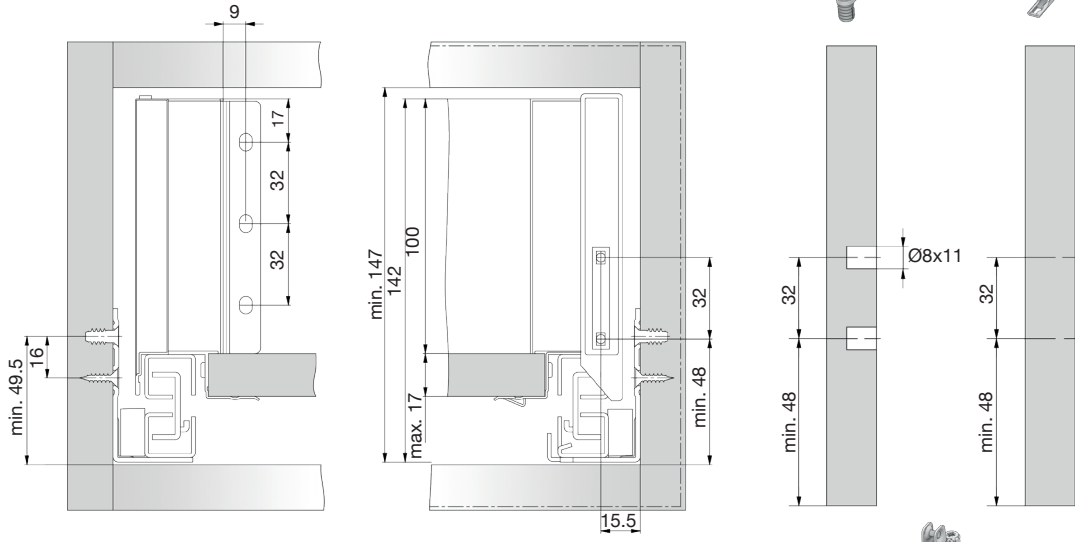

DW145

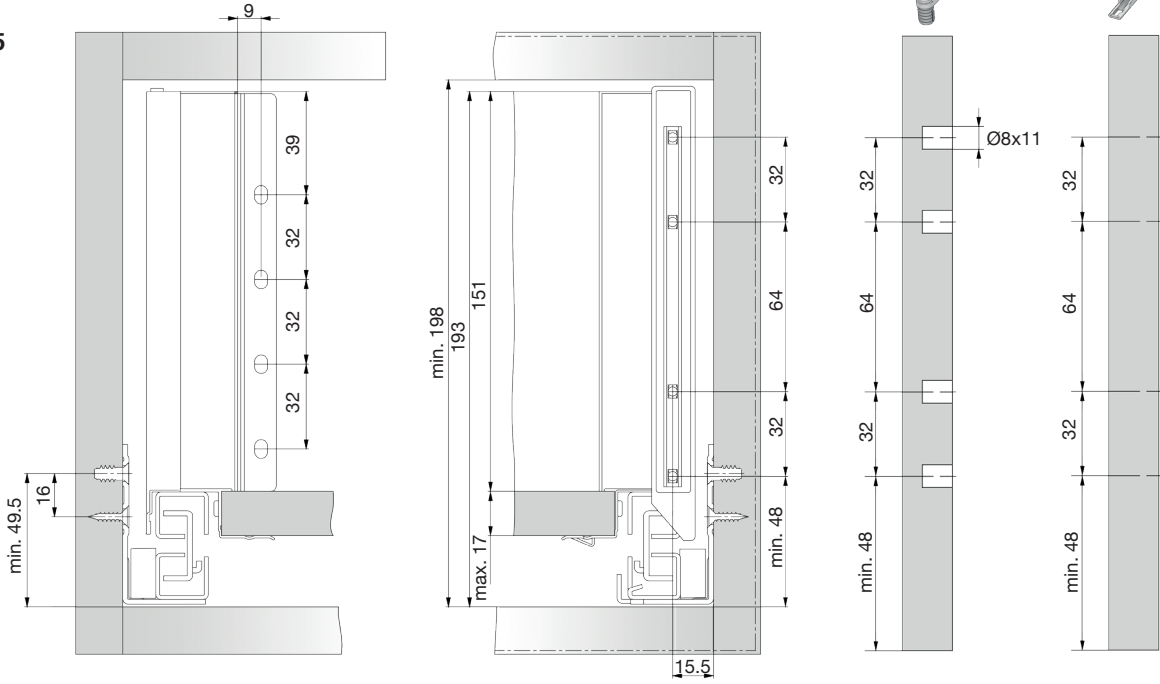

DW182

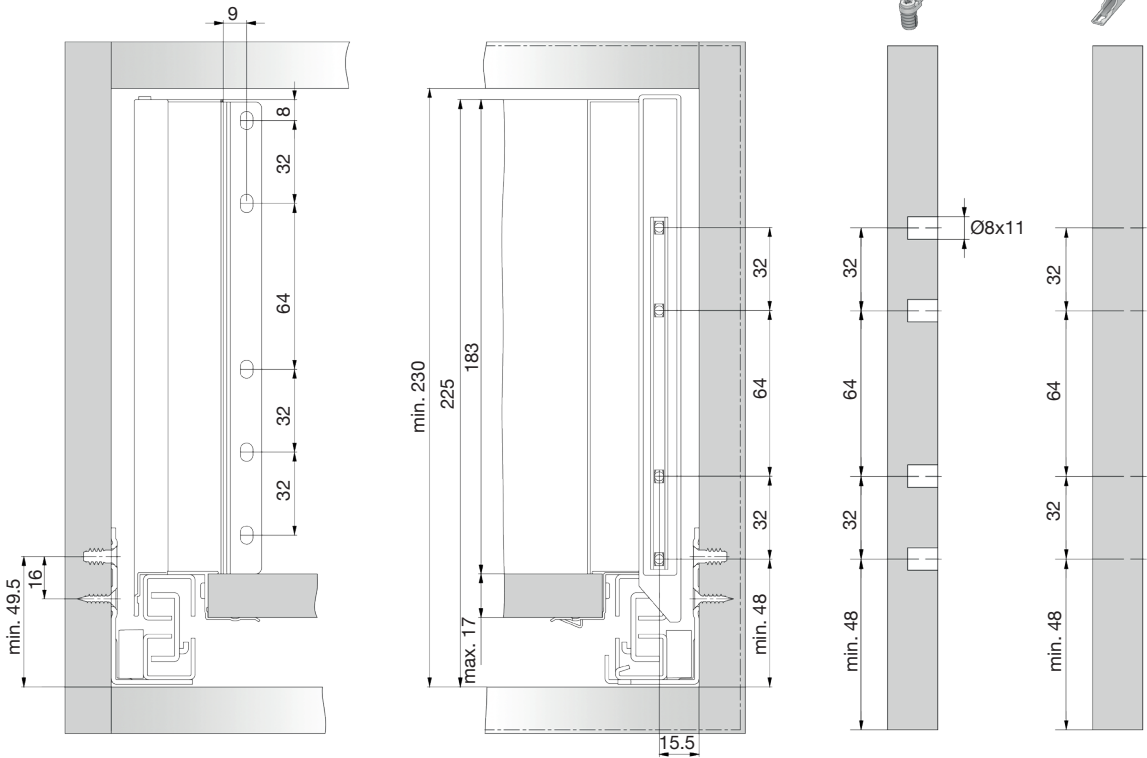

Assembly wooden back panel

1

2x

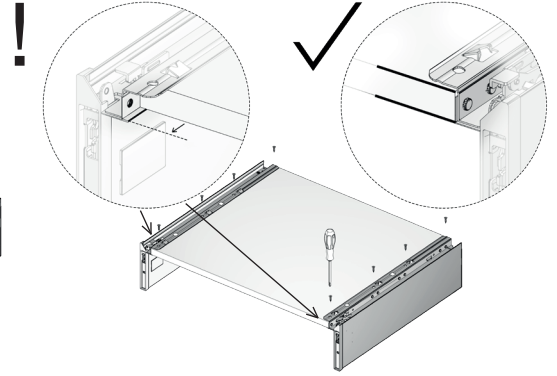
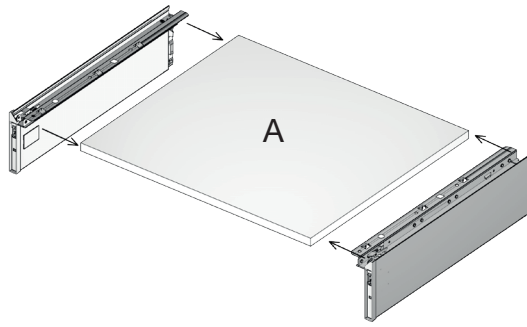

8x

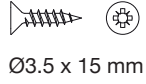

2

2x

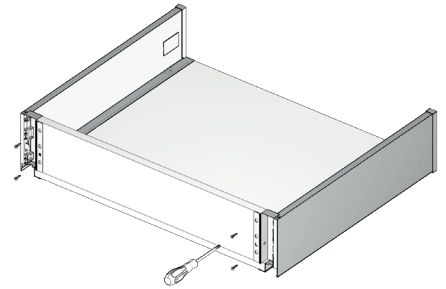
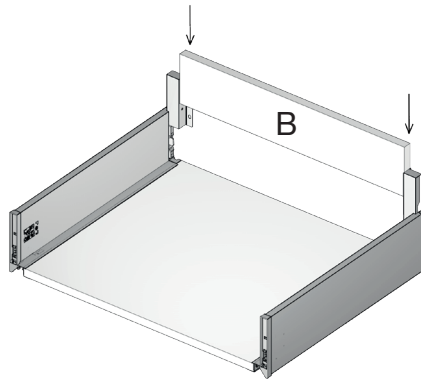

4x

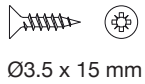

Assembly steel back panel

1

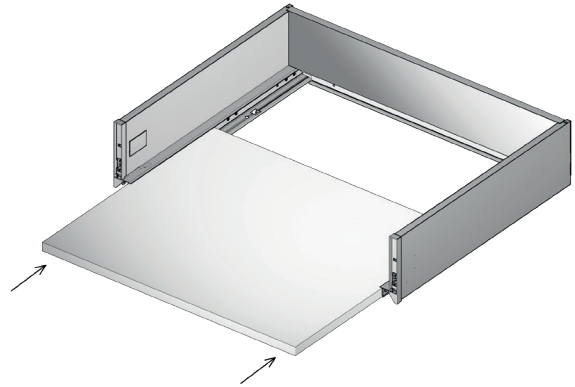
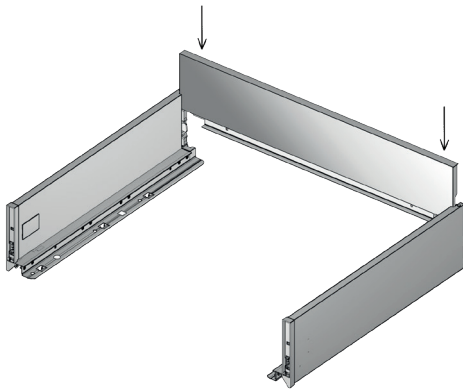

2

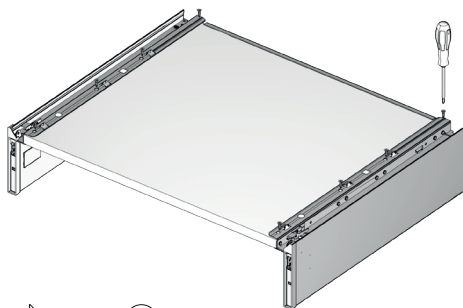

8x

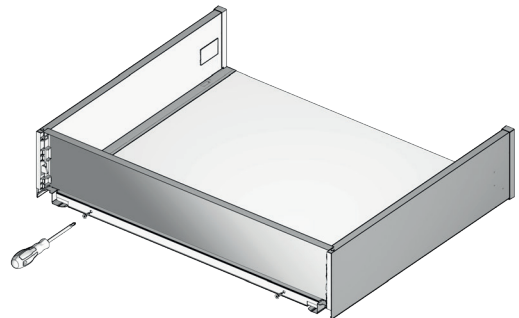
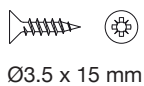

2x

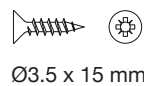

Insertion of Front Connectors

3

2x

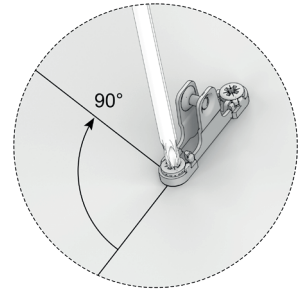
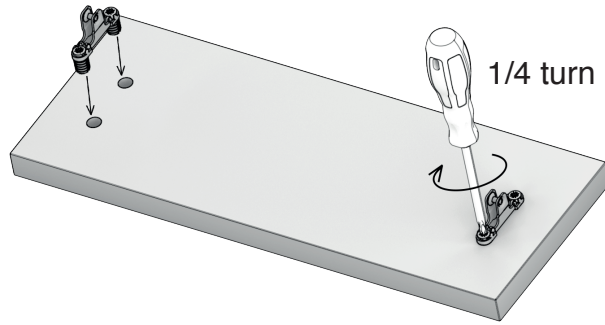
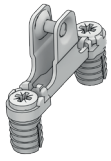

2x

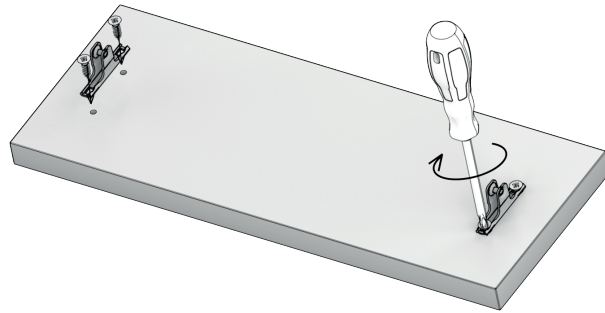
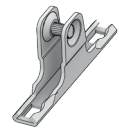

4x



Ø3.5 x 15 mm

Front Panel Mounting

4

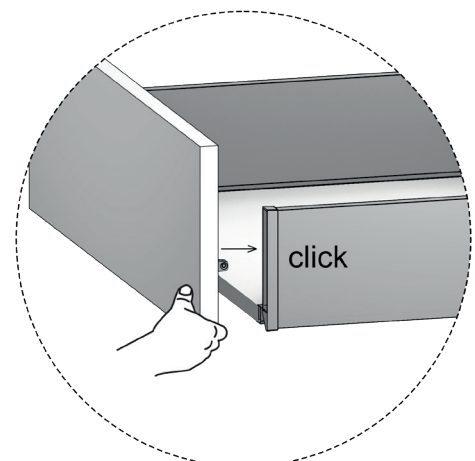
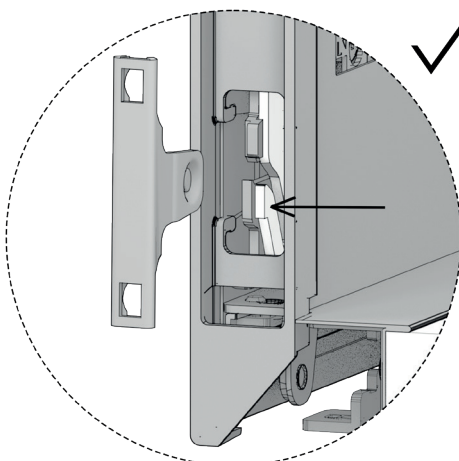
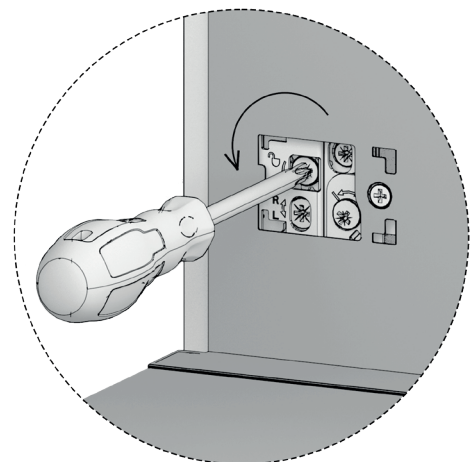
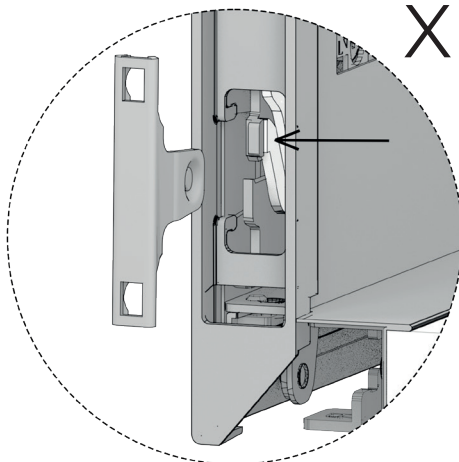

Drawer Insertion

5

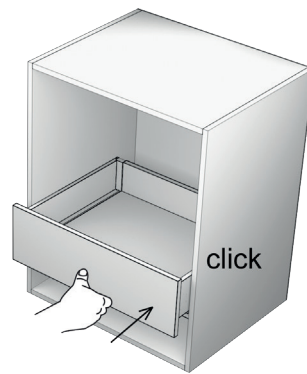
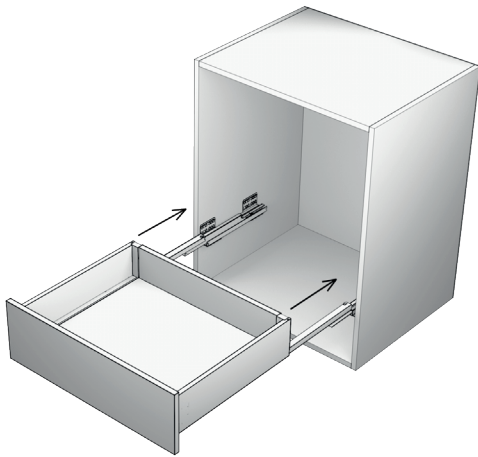

Adjustments

i

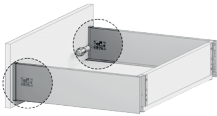

Side adjustment

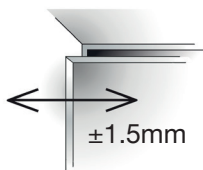

Height adjustment

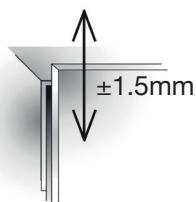

Tilt adjustment

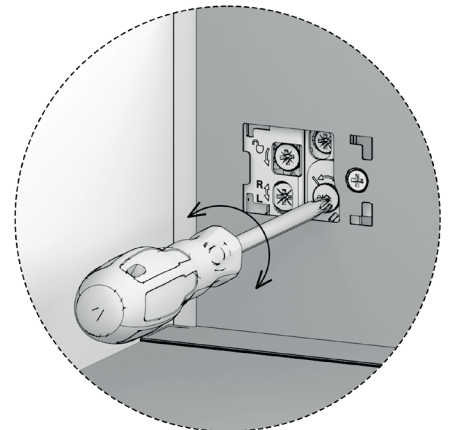
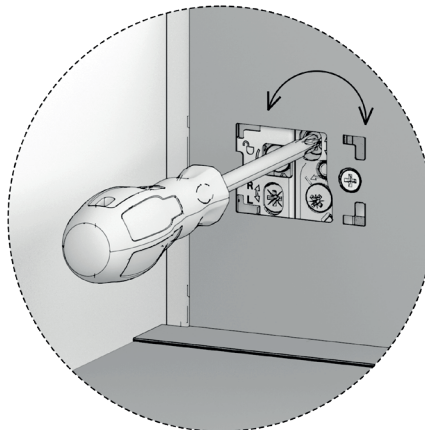
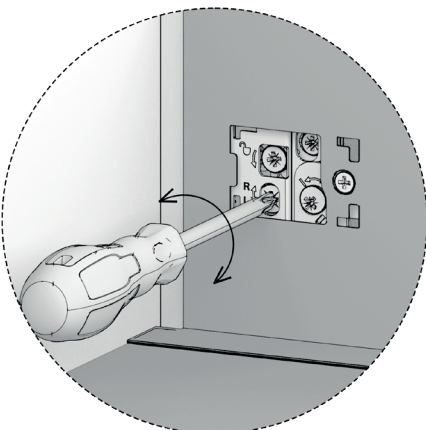
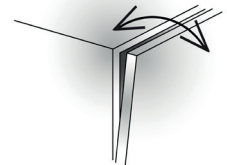

Drawer removal

1

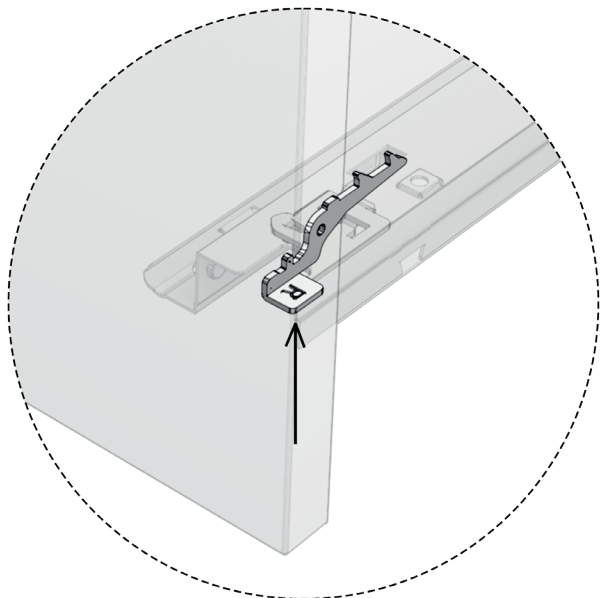
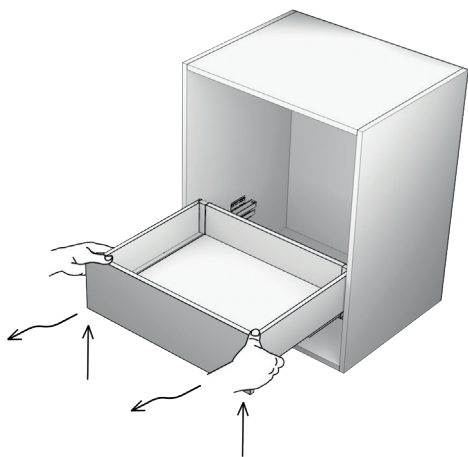

2

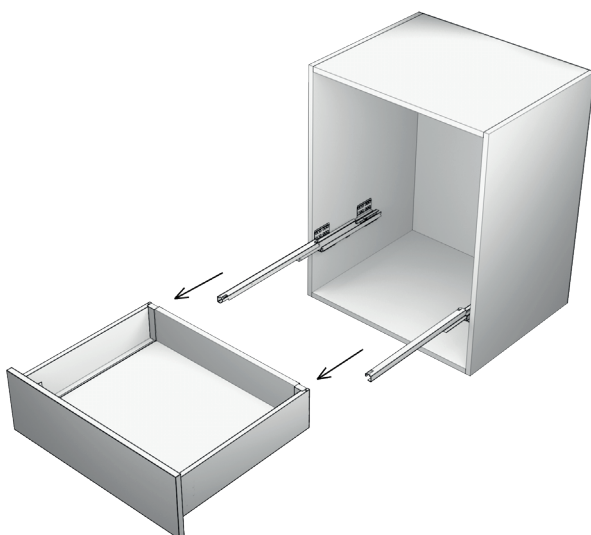

Front panel removal

i

